

11.2 E3ISPM Series C-mount USB3.0 CMOS Camera with Hardware ISP and Video Pipeline (32)

11.2.1 The Basic Characteristic of E3ISPM Series

E3ISPM series adopt SONY Exmor CMOS sensor as the image-picking device and USB3.0 is used as the transfer interface.

E3ISPM series hardware resolutions range from 1.5M to 45M and come with the integrated CNC aluminum alloy compact housing.

E3ISPM series integrated with 12 bit Ultra-Fine Hardware Image Signal Processor Video Pipeline(Ultra-Fine HISP VP) for Demosaic, Automatic Exposition, Gain Adjustment, One Push White Balance, Chrominance Adjustment, Saturation Adjustment, Gamma Correction, Luminance Adjustment, Contrast Adjustment, Bayer and finally form RAW data for 8/12 bit output. This will move the heavier burden of the processing from the PC to the Ultra-Fine HISP VP and greatly accelerating the processing speed.

E3ISPM series comes with advanced video & image processing application ToupView/ToupLite; Providing Windows/Linux/ macOS /Android multiple platform SDK (Native C/C++, C#/VB.NET, Python, Java, DirectShow, Twain, etc);

The E3ISPM series can be widely used in bright field light environment and microscope image capture and analysis with higher frame rate.

The basic characteristic of E3ISPM series are as follows:

- SONY Exmor, Exmor R(Back-illuminated), Exmor RS CMOS sensor with USB3.0 interface;
- Real-time 8/12bit depth switch(depending on sensor);
- Ultra-Fine HISP VP and USB3.0 5 Gbps interface ensuring high frame rates;
- Super high sensitivity up to 2188mV(IMX264);
- Ultra-low noise and low power dissipation by using column-parallel A/D conversion;
- With hardware resolution among 1.5M to 45M;
- Rolling shutter or global shutter;
- Standard C-Mount camera;
- CNC aluminum alloy housing;
- With advanced video & image processing application ToupView/ToupLite;
- Providing Windows/Linux/Mac OS multiple platforms SDK;
- Native C/C++, C#/VB.Net, DirectShow, Twain, LabView



11.2.2 E3ISPM Series Datasheet (33)

Order Code	Sensor & Size(mm)	Pixel(μm)	G Sensitivity Dark Signal	FPS/Resolution	Binning	Exposure
E3ISPM45000KPA IP145000A(2021)	45M/IMX294(C,RS) 1.4" (18.93x13.00)	2.315x2.315	108mv with 1/30s 0.03mv with 1/30s	8.1@8176x5616 30.0@4088x2808 8.1@7408x5556 33.0@4088x2808 10.4@8176x4320 34.7@4096x2160 62.5@2048x1080 86.5@1344x720	1x1(3:2) 2x2(3:2) 1x1(4:3) 2x2(4:3) 1x1(17:9) 2x2(17:9) 3x3(17:9) 4x4(17:9)	0.1ms~15s
E3ISPM45000KPB IP145000B(2022)	45M/IMX492(C,RS) 1.4" (18.93x13.00)	2.315x2.315	108mv with 1/30s 0.03mv with 1/30s	8.1@8176x5616(C) 30.0@4080x2808(M) 8.1@7408x5556(C) 33.0@3696x2778(M) 10.4@8176x4320(C) 34.7@4096x2160(M) 62.5@2048x1080(M) 86.5@1344x720(M)	1x1(3:2) 2x2(3:2) 1x1(4:3) 2x2(4:3) 1x1(17:9) 2x2(17:9) 3x3(17:9) 4x4(17:9)	0.1ms~15s
E3ISPM32000KPA IP132000A(2021)	32M/IMX294(C,RS) 1.15" (12.96x12.96)	2.315x2.315	108mv with 1/30s 0.03mv with 1/30s	8.1@5600x5600 30.0@2800x2800 30.0@1400x1400	1x1 2x2 4x4	0.1ms~15s
E3ISPM25000KPA IP125000A(20220808)	25M/IMX511(C,RS) 1/2.3" (5.519x5.519)	1.12x1.12	96.3mv with 1/30s 0.1mv with 1/30s	12@4928x4928 46@2464x2464 100@1648x1648	1x1 2x2 3x3	0.013ms~15s
E3ISPM21000KPA IP121000A(2020)	21M/IMX269(C) 4/3" (17.4x13.0)	3.3 x3.3	399mv with 1/30s 0.1mv with 1/30s	17@5280x3954 17@3952x3952 56@2640x1976 67@1760x1316 192@584x438	1x1 1x1 2x2 3x3 9x9	0.1ms~15s
E3ISPM20400KPA IP120400A 20230326	20.4M/IMX541(C,GS) 1.1" (12.32x12.32)	2.74 x2.74	1574mv with 1/30s 0.15mv with 1/30s	17.5@4496x4496 64.4@2240x2240 64.4@1120x1120	1x1 2x2 4x4	0.03ms~15s
E3ISPM20000KPA IP120000A	20M/IMX183(C,RS) 1" (13.06x8.76)	2.4 x2.4	462mv with 1/30s 0.21mv with 1/30s	15@5440x3648 50@2736x1824 60@1824x1216	1x1 2x2 3x3	0.1ms~15s
E3ISPM20000KPD	20M/IMX283(C,RS) 1" (13.06x8.76)	2.4 x2.4	462mv with 1/30s 0.21mv with 1/30s	15@5440x3648 50@2736x1824 60@1824x1216	1x1 2x2 3x3	0.1ms~15s
E3ISPM20000KPC IP120000C(2021)	20M/IMX183(C,RS) 1" (13.06x8.76)	2.4 x2.4	462mv with 1/30s 0.21mv with 1/30s	20@5440x3648 48@2736x1824 58@1824x1216	1x1 2x2 3x3	0.1ms~15s
E3ISPM18000KPA IP118001A	18M/SONY Special(C,RS) 1/2.2" (5.86x4.46)	1.2 x1.2	130mv with 1/30s 0.1mv with 1/30s	17@4880x3720 40@2448x1836 50@1728x1296	1x1 2x2 3x3	0.1ms~15s
E3ISPM15600KPA IP115600A	15.6M/SONY Special (C,RS) 1.1" (13.0x13.0)	3.3 x3.3	399mv with 1/30s 0.1mv with 1/30s	17@3952x3952 56@1976x1976 67@1316x1316	1x1 2x2 3x3	0.1ms~15s
E3ISPM12400KPA IP112400A 20230326	12.4M/IMX545(C,GS) 1/1.1" (11.22x8.22)	2.74 x2.74	1337mv with 1/30s 0.15mv with 1/30s	28.2@4096x3000 100.9@2048x1500 100.9@1024x750	1x1 2x2 4x4	0.03ms~15s
E3ISPM12300KPA IP112300A	12.3M/IMX304(C,GS) 1.1" (14.13x10.35)	3.45x3.45	1146mv with 1/30s 0.1mv with 1/30s	23.4@4096x3000 46.3@2048x1500	1x1 1x1	0.244ms~15s
E3ISPM12000KPA IP112000A	12M/IMX226(C,RS) 1/1.7" (7.40x5.55)	1.85x1.85	280mv with 1/30s 0.1mv with 1/30s	25@4000x3000 50@2048x1080	1x1 2x2	0.1ms~15s
E3ISPM12000KPB IP112000B(2022)	12M/IMX577(C,RS) 1/2" (6.29x4.71)	1.55x1.55	250mv with 1/30s 0.25mv with 1/30s	30@4056x3040 60@2028x1520 120@1014x760	1x1 2x2 4x4	0.1ms~5s
E3ISPM12000KPC IP112000C(20230717)	12M/IMX676(C,RS) 1/1.6" (7.07x7.07)	2.0x2.0	3637mv with 12 bit converted value(HCG) 0.15mv with 1/30s	27@3536x3536 60@1768x1768	1x1 2x2	0.013ms~15s
E3ISPM09000KPA IP109000A	9.0M/IMX305(C,GS) 1" (14.13x7.45)	3.45x3.45	1146mv with 1/30s 0.15mv with 1/30s	34@4096x2160 60@2048x1080	1x1 1x1	0.1ms~15s
E3ISPM09000KPB IP109000B	9.0M/IMX533(C,RS) 1" (11.31x11.28)	3.76x3.76	535mv with 1/30s 0.04mv with 1/30s	40@3008x3000 123@1488x1500 186@992x998	1x1 2x2 3x3	0.013ms~15s
E3ISPM08300KPA IP108300A	8.3M/IMX274(C,RS) 1/2.5" (6.22x3.50)	1.62x1.62	236mv with 1/30s 0.1mv with 1/30s	32@3840x2160 65@1920x1080	1x1 2x2	0.244ms~15s
E3ISPM08300KPB IP108300B	8.3M/IMX334(C,RS) 1/1.8" (7.68x4.32)	2.0x2.0	505mv with 1/30s 0.1mv with 1/30s	35@3840x2160 60@1920x1080	1x1 2x2	0.02ms~15s
E3ISPM08300KPC IP108300C	8.3M/IMX485(C,RS) 1/1.2" (11.14x6.26)	2.9x2.9	2188mv with 1/30s 0.15mv with 1/30s	45@3840x2160 60@1920x1080	1x1 2x2	0.02ms~15s
E3ISPM08300KPD IP108300D(2022)	8.3M/IMX585(C,RS) 1/1.2" (11.14x6.26)	2.9x2.9	5970(mV/lx/s) 0.13mv with 1/30s	45@3840x2160 60@1920x1080	1x1 2x2	0.02ms~15s
E3ISPM08300KPE	8.3M/IMX678(C,RS)	2.0x2.0	3541(mV/lx/s)	45@3840x2160	1x1	0.02ms~15s

E3ISPM Series C-mount USB3.0 CMOS Camera with Hardware ISP and Video Pipeline

IP108300E(2022)	1/1.8”(7.68x4.32)		0.15mv with 1/30s	60@1920x1080	2x2	
E3ISPM08000KPA IP108000A	8.0M/IMX294(C,RS) 1.15”(13.00x13.00)	4.63 x4.63	419mv with 1/30s 0.12mv with 1/30s	30@2808x2808(14bit) 139@1392x1392 139@696x696	1x1 2x2 4x4	0.1ms~15s
E3ISPM06300KPA IP106300A	6.3M/IMX178(C,RS) 1/1.8”(7.37x4.92)	2.4x2.4	425mv with 1/30s 0.15mv with 1/30s	30@3072 x2048 38@1536x 1024	1x1 2x2	0.24ms~15s
E3ISPM06300KPB IP106300B	6.3M/IMX178(C,RS) 1/1.8”(7.37x4.92)	2.4x2.4	425mv with 1/30s 0.15mv with 1/30s	59@3072 x2048 59@1536x 1024	1x1 2x2	0.02ms~15s
E3ISPM05100KPA IP105100A 20230326	5.1M/IMX547(C,GS) 1/1.8”(6.71x5.61)	2.74x2.74	1337mv with 1/30s 0.15mv with 1/30s	63@2448x2048 208.4@1224x1024	1x1 2x2	0.03ms~15s
E3ISPM05000KPA IP105000A	5.0M/IMX264(C,GS) 2/3”(8.45x7.07)	3.45x3.45	1146mv with 1/30s 0.15mv with 1/30s	35@2448x2048 50@1224x1024	1x1 1x1	0.1ms~15s
E3ISPM03100KPA IP103100A	3.1M/IMX265(C,GS) 1/1.8”(7.07x5.30)	3.45x3.45	1146mv with 1/30s 0.15mv with 1/30s	53@2048x1536 85@1024x768	1x1 1x1	0.1ms~15s
E3ISPM03100KPB IP103100B	3.1M/IMX123(C,RS) 1/2.8”(5.12x3.84)	2.5x2.5	600mv with 1/30s 0.15mv with 1/30s	50@2048x1536 50@1920x1080	1x1 1x1	0.1ms~15s
E3ISPM02100KPA IP102100A(2021)	2.1M/IMX482(C,RS) 1/1.2”(11.14x6.26)	5.8x5.8	8935mv with 1/30s 0.6mv with 1/30s	96@1920x1080	1x1	14us~15s
E3ISPM02000KPA IP102000A	2M/IMX385(C,RS) 1/2”(7.2x4.05)	3.75x3.75	2350mv with 1/30s 0.15mv with 1/30s	125@1920x1080	1x1	0.26ms~15s
E3ISPM01500KPA IP101500A	1.5M/IMX273(C,GS) 1/2.9”(4.968x3.726)	3.45x3.45	1146mv with 1/30s 0.15mv with 1/30s	164@1440x1080 320@720x540	1x1 2x2	0.1ms~15s

C: Color; M: Monochrome; GS: Global Shutter

Other Specification	
Spectral Range	380-650nm (with IR-cut Filter)
White Balance	ROI White Balance/ Manual Temp Tint Adjustment/NA for Monochromatic Sensor
Color Technique	Ultra-Fine HISPVP /NA for Monochromatic Sensor
Capture/Control SDK	Windows/Linux/macOS/Android Multiple Platform SDK(Native C/C++, C#/VB.NET, Python, Java, DirectShow, Twain, etc)
ADC	8 Bit / 12 Bit
Recording System	Still Picture and Movie
Cooling System*	Natural
Operating Environment	
Operating Temperature(in Centidegree)	-10~ 50
Storage Temperature(in Centidegree)	-20~ 60
Operating Humidity	30~80%RH
Storage Humidity	10~60%RH
Power Supply	DC 5V over PC USB3. 0 Port. Compatible with USB2.0
Software Environment	
Operating System	Microsoft® Windows® XP / Vista / 7 / 8 / 10 / 11 (32 & 64 bit) OSx(Mac OS X) Linux
PC Requirements	CPU: Equal to Intel Core2 2.8GHz or Higher
	Memory: 2GB or More
	USB Port: USB3.0 High-speed Port
	Display: 17” or Larger CD-ROM

11.2.3 Dimension of E3ISPM Series

The E3ISPM series body, made from tough, CNC aluminum alloy, ensures a heavy duty, workhorse solution. The camera is designed with a high quality IR-CUT to protect the camera sensor. No moving parts included. This design ensures a rugged, robust solution with an increased lifespan when compared to other industrial camera solutions.

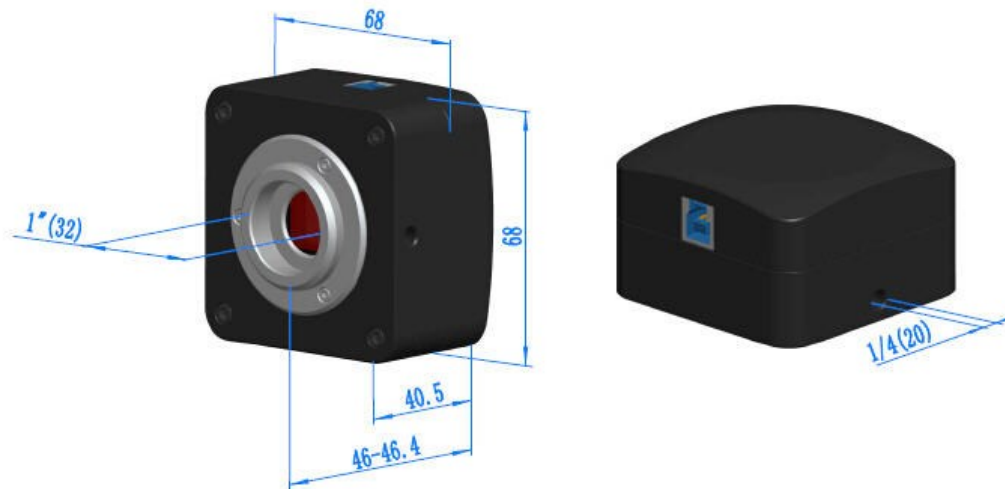

Dimension of E3ISPM Series





11.2.4 Packing Information for E3ISPM Series



Packing Information of E3ISPM Series

Standard Camera Packing List			
A	Carton L:52cm W:32cm H:33cm (20pcs, 12~17Kg/ carton), not shown in the photo		
B	Gift box L:15cm W:15cm H:10cm (0.58~0.6Kg/ box)		
C	One E3ISPM series camera		
D	High-speed USB3.0 A male to B male gold-plated connectors cable /2.0m		
E	CD (Driver & utilities software, Ø12cm)		
Optional Accessory			
F	Adjustable lens adapter	C-mount to Dia.23.2mm eyepiece tube (Please choose 1 of them for your microscope)	108001/AMA037 108002/AMA050 108003/AMA075 108004/AMA100
		C-mount to Dia.31.75mm eyepiece tube (Please choose 1 of them for your telescope)	108008/ATA037 108009/ATA050 108010/ATA075 108011/ATA100
G	Fixed lens adapter	C-mount to Dia.23.2mm eyepiece tube (Please choose 1 of them for your microscope)	108005/FMA037 108006/FMA050 108007/FMA075 108008/FMA100
		C-Mount to Dia.31.75mm eyepiece tube (Please choose 1 of them for your telescope)	108011/FTA037 108012/FTA050 108013/FTA075 108014/FTA100
Note: For F and G optional items, please specify your camera type(C-mount, microscope camera or telescope camera) , ToupTek engineer will help you to determine the right microscope or telescope camera adapter for your application;			
H	108015(Dia.23.2mm to 30.0mm ring)/Adapter rings for 30mm eyepiece tube		
I	108016(Dia.23.2mm to 30.5mm ring)/ Adapter rings for 30.5mm eyepiece tube		
J	108017(Dia.23.2mm to 31.75mm Ring)/ Adapter rings for 31.75mm eyepiece tube		
K	Calibration kit	106011/TS-M1(X=0.01mm/100Div.);	
		106012/TS-M2(X,Y=0.01mm/100Div.);	
		106013/TS-M7(X=0.01mm/100Div., 0.10mm/100Div.)	

11.2.5 Extension of E3ISPM Series with Microscope or Telescope Adapter

Extension	Picture	
C-mount Camera	 <p data-bbox="852 383 1238 501">Machine vision; Medical imaging; Semiconductor equipment; Test instruments; Document scanners; 2D barcode readers; Web camera and security video; Microscope imaging;</p>	
Microscope Camera	 <p data-bbox="432 887 767 909">E3ISPM+AMAXXX(23.2mm Adapter)</p>  <p data-bbox="967 887 1302 909">E3ISPM+FMAXXX(23.2mm Adapter)</p>	
Telescope Camera	 <p data-bbox="432 1146 767 1169">E3ISPM+ATAXXX(31.75mm Adapter)</p>  <p data-bbox="967 1146 1302 1169">E3ISPM+FTAXXX(31.75mm Adapter)</p>	